

## DESIGNER SERIES WHITES

Architectural design quality LED modules for use with Covelum™ LED, create color temperature specific illumination for recessed applications.

CAT:	FEET:
TYPE:	PROJECT:

### FEATURES

- Critical white color applications within +/-50°K, recommended for illumination within 6" of source and for white backgrounds
- Flexible field cuttable dual wire system bends 90° easily to fit concave and convex curves without special hardware
- Designer quality LED modules create specific white illumination
- Low maintenance, energy efficient lighting for high or low ambient light interior applications
- More information on Tivoli Designer Series Colormix available at [www.TIVOLICOLORMIX.com](http://www.TIVOLICOLORMIX.com)
- Full range dimming available

### SPECIFICATIONS

COVELUM LED DESIGNER WHITES	EFFICACY LM/WT	CRI	LM/FT	LM/MODULE	WT/FT	WT/MODULE
Warm White (2400°K) at 2.5" O.C.	<b>38.47</b>	39.3	138.48	28.85	3.6	0.75
Warm White (2600°K) at 2.5" O.C.	<b>59.54</b>	40.1	214.37	44.66	3.6	0.75
Warm White (2800°K) at 2.5" O.C.	<b>64.2</b>	54.8	231.12	48.15	3.6	0.75
Warm White (3000°K) at 2.5" O.C.	<b>64.75</b>	54.9	233.09	48.56	3.6	0.75
Warm White (3200°K) at 2.5" O.C.	<b>65.29</b>	59.5	235.06	48.97	3.6	0.75
White (5000°K) at 2.5" O.C.	<b>66.41</b>	63.3	239.09	49.81	3.6	0.75
White (5500°K) at 2.5" O.C.	<b>72.8</b>	77.7	262.08	54.6	3.6	0.75

Items in bold denote Title 24 High efficacy rating. Measurements are based on 12V DC power and 0.75W design calculations will vary based on power supply and run lengths.

LED DATA RATED TO LM80 STANDARDS	WATTAGE	LED LIFE* / COLOR TEMP	VIEWING ANGLE
LED Superflux module with 6 Triple Chip LEDs	0.75W per PCB	<b>30,000 hrs.</b> All White color temperatures	150°

\* Ultra Bright Triple Chip LEDs are manufactured on fuse style PCB modules in 2 each 3 LED series orientation and operate at 52% of LED manufacturers maximum current spec rating.

1. **Spacing** - Lamp spacing: 2.5", 3", 4" O.C.
2. **LED PCB** - Uses 0.75W, 12VDC LED modules in fuse style envelope
3. **Adjustability** - +/-45° Directional LED modules (90° total adjustability) offer the ability to manually set the angular throw of light individually, distributing light over a 150° beam spread
4. **Color Temperatures**  
6 color temperatures of Warm White (2400°-3400°K)  
4 color temperatures of Pure White (4500°-6000°K)  
3 color temperatures of Cool White (7000°-9000°K)
5. **Mounting** - Aluminum mounting channel for linear mounting or mounting clamps (2 per foot) for curved or arched applications
6. **Lens** - Linear lens mounts in channel to protect LEDs from direct contact
7. **Max run length** - Continuous: 50' (215 PCB's per 15A circuit)
8. **Power Supply** - Listed Class I or II 12V DC power supply required
9. **Listing** - ETL dry listed for indoor Class I or II applications
10. **Warranty** - 3 Year Warranty



Covelum™ LED with 2.5" O.C. Super Flux Modules

### PROFILES

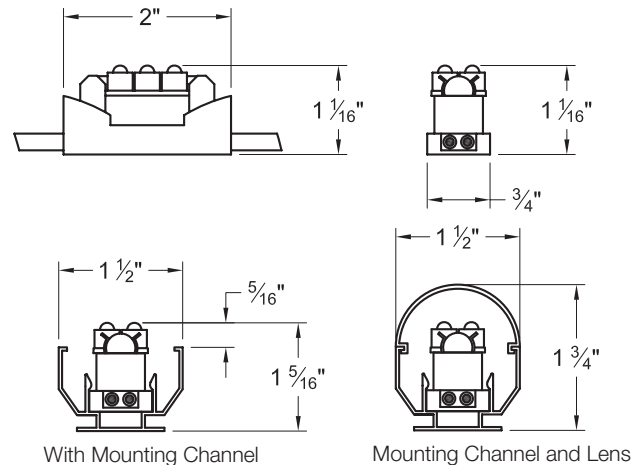

### COVELUM LED ORDER SPECIFICATION GUIDE

Example: CLL-DS-2.5-WW-24-12

PRODUCT CODE	LED TYPE	LED SPACING	COLOR TYPE	TEMPERATURE	VOLTAGE	REQUIRED POWER SUPPLY
CLL	DS	2.5 = 2.5" O.C. 3.0 = 3" O.C. 4.0 = 4" O.C.	WW = Warm White WH = White CW = Cool White	<b>Warm Whites</b> 24=2400°K 26=2600°K 28=2800°K 30=3000°K 32=3200°K <b>Whites</b> 45=4500°K 50=5000°K 55=5500°K 60=6000°K <b>Cool Whites</b> 70=7000°K 80=8000°K 90=9000°K	12	PSU <small>See power supply specsheets</small>
					12 = 12VDC	

### REQUIRED POWER SUPPLY OPTIONS

- ADUL-300-5-5-12-D
- ADUL-200-3-5-12-D
- ADUL-200-1-15-12-D
- ADUL-75-1-5-12-D
- QT-200-1-15-12-D
- QTH-200-1-15-12-D
- QT-400-2-15-12-D
- QTH-400-2-15-12-D
- QT-600-3-15-12-D
- QTH-600-3-15-12-D
- JT-240-4-5-12-D
- JTH-240-4-5-12-D
- JT-60-1-5-12-D
- JTH-60-1-5-12-D
- MT-60-1-5-12-D

### OPTIONAL DIMMERS

- N-600
- N-1000
- N-1500
- NH-600
- NH-1000
- DIM-12V-8A
- DIM-OT-1-5-D

See power supply specifications for more information

Copyright © 2012 Tivoli 2.29.12 - Page 1 of 4



# COVELUM™ DESIGNER SERIES LED WHITES

## MOUNTING ACCESSORIES



**CLL-MC Mounting Clamp**  
Clear polycarbonate mounting clamp secures Covelum™ cable to surface with a single screw on each side of clamp. (Screws not provided.)



**CLL-CHAN-8 Aluminum Mounting Channel**  
For straight run applications. Channel screws in place, lamp sockets fit into channel ensuring linear integrity and reducing installation time. The finish is standard satin aluminum. Comes in 8' sections.

### Lighting Effects Accessories.

Mounting clamps are recommended as a standard mounting accessory. This method is effective for curved or straight applications. Mounting clamps should be placed every 6".

Mounting channel is recommended for uneven mounting surfaces or when applications require a cover. Clear lens covers are used to protect the Covelum LED modules from the environment without diminishing light output.

Opaque and Frosted lens covers are used to not only protect the Covelum LED module but to soften light for an even glow. Covelum LED module selection in conjunction with the opaque lens, is for low ambient or near dark light levels.

## WIRING ACCESSORIES



**CLL-JBOX Junction Box**  
Use to cover terminal block connections. One end of the terminal block screws directly into the Covelum™ LED lead wires, the other end accepts AWG # 10, 12, 14 wire from power supply. 1 each terminal block included.

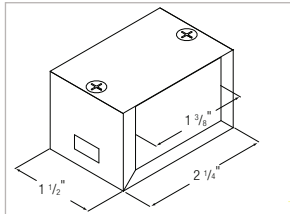

**CLL-EC End Caps**  
Each length of Covelum™ LED can be terminated with PVC end caps to protect and insulate the conductors at the end of a run.

## ACCESSORIES & REPLACEMENTS



**CLL-LENS-C-8 Clear Lens**  
**CLL-LENS-O-8 Opaque Lens**  
**CLL-LENS-F-8 Frosted Lens**  
Clear, opaque and frosted polycarbonate lens for channel, shields and protects lamps from direct contact. Comes in 8' sections (opaque lens shown).  
**CLL-CH-EC Channel End Caps** available



**REPLACEMENT PCB MODULES**  
**CLL-DS-WW-24-12** Warm White 2400°K  
**CLL-DS-WW-26-12** Warm White 2600°K  
**CLL-DS-WW-28-12** Warm White 2800°K  
**CLL-DS-WW-30-12** Warm White 3000°K  
**CLL-DS-WW-32-12** Warm White 3200°K  
**CLL-DS-WW-45-12** White 4500°K  
**CLL-DS-WW-50-12** White 5000°K  
**CLL-DS-WW-55-12** White 5500°K  
**CLL-DS-WW-60-12** White 6000°K  
**CLL-DS-WW-70-12** Cool White 7000°K  
**CLL-DS-WW-80-12** Cool White 8000°K  
**CLL-DS-WW-90-12** Cool White 9000°K



**REPLACEMENT STRAND\***  
**CLL-RS-2.5** Replacement Strand - 2.5" O.C.  
**CLL-RS-3.0** Replacement Strand - 3.0" O.C.  
**CLL-RS-4.0** Replacement Strand - 4.0" O.C.  
\* Not including LED PCB modules

# COVELUM™ DESIGNER SERIES LED WHITES

## FIXTURE SELECTION

### Lamp Type

SF: Super Flux modules offer a high intensity wide area of light for use in bright ambient light conditions. SF modules are 0.75W, 12V DC, with 6 LEDs manufactured in warm white and white with a 150° viewing angle.

### Lamp Spacing

To select the lamp spacing necessary for desired effect, choose a close spacing for an even unbroken glow when you have a close distance or a wider spacing for a softer light with a greater distance to the wall area to be lit. (see lamp spacing chart for details)

## LAMP SPACING GUIDE

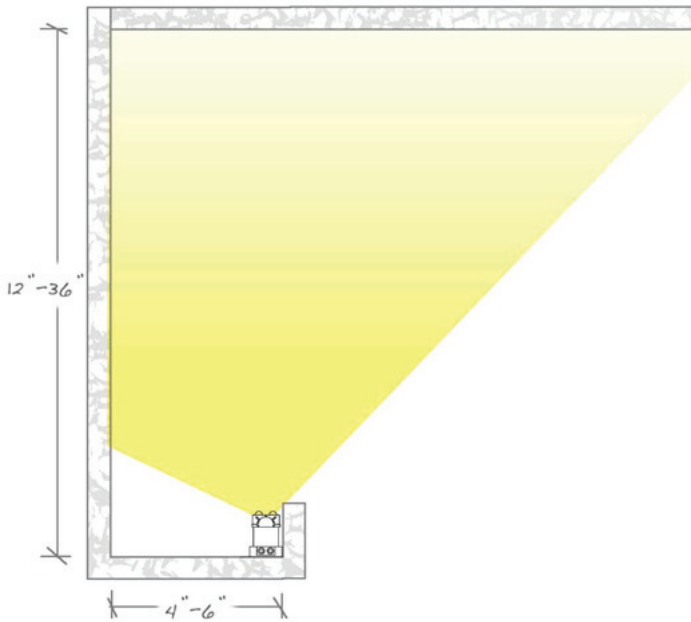

For interior critical white color applications within +/- 50K, recommended for illumination within 6" of source and for white backgrounds. Set back 6-12", cove height 1-4'.

## MTBF

**Mean Time Between Failures (MTBF) for LEDs:** While Tivoli utilizes LEDs provided by industry leading vendors, these are electrical components with calculated manufacturers mean time between failures (MTBF). MTBF is rated as the average point at which 1/2 of color LEDs will lose 50% of their original brightness. MTBF for White LEDs is based on when 1/2 are reduced to 70% of their original brightness.

Typically, LED product failures occur within fixture construction, interdependent component failure, or operation under adverse conditions. Tivoli operates LEDs at a derated current to insure that LED MTBF values are based on product fixture construction and real application standards.

Still, conditions such as excessive voltage, vibration, heat, and other adverse conditions may negatively effect the life of LEDs.

## Lamp Color

Lamp color selections can accent the hidden color within a surface, bringing out details or patterns not seen in a broad spectrum of light. Tivoli™ uses a range of 2600K to 3200K for warm white and 5000K to 6000K for white. Color temperatures are created by manufacturer LED modules that blend different color bins together to achieve rich color temperatures. Individual orders will be bin-sorted to within plus or minus 100K and it is recommended to purchase 10% replacement stock within that bin lot to insure matched color for needed replacements. Individual modules will vary in color and application design needs to incorporate cross blending to create color uniformity. Tivoli's Covelum LED product is intended for use as an indirect cove lighting product. Use in direct view or backlit applications may not yield acceptable results.

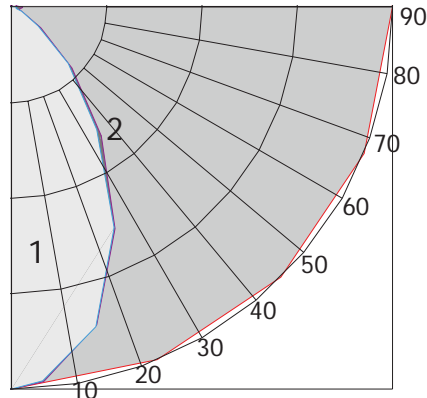

Maximum Candela = 138 Located At Horizontal Angle = 0, Vertical Angle = 0  
 # 1 - Vertical Plane Through Horizontal Angles (0 - 180) (Through Max. Cd.) : BLUE  
 # 2 - Vertical Plane Through Horizontal Angles (90 - 270) : MAGENTA  
 # 3 - Horizontal Cone Through Vertical Angle (0) (Through Max. Cd.) : RED  
 For more details on the IES Photo Metrics Graph, visit <http://www.tivolilighting.com/prodsearch.htm> under COVE LIGHTING.

## COEFFICIENTS OF UTILIZATION - ZONAL CAVITY METHOD

Effective Floor Cavity Reflectance 0.20

RC	80				70				50			30			10			0
	70	50	30	10	70	50	30	10	50	30	10	50	30	10	50	30	10	0
0	118	118	118	118	115	115	115	115	109	109	109	103	103	103	98	98	98	95
1	109	104	101	97	106	102	98	95	97	94	91	92	90	88	88	86	84	82
2	100	93	87	82	97	91	85	81	87	82	78	83	79	76	79	76	73	71
3	93	83	76	70	90	82	75	70	78	72	68	75	70	66	72	68	64	62
4	86	75	67	61	83	73	66	60	70	64	59	68	62	58	65	60	57	54
5	79	68	60	54	77	66	59	53	64	57	52	61	56	51	59	54	50	48
6	74	61	53	47	71	60	53	47	58	51	46	56	50	45	54	49	45	43
7	68	56	48	42	66	55	47	42	53	46	41	51	45	41	49	44	40	38
8	64	51	43	38	62	50	43	37	49	42	37	47	41	36	46	40	36	34
9	60	47	39	34	58	46	39	34	45	38	33	43	37	33	42	37	33	31
10	56	43	36	31	54	43	35	31	41	35	30	40	34	30	39	34	30	28

## LED BINNING

LED's are made in lots and sorted into bins based on wavelength ranges that achieve colors. Tivoli uses a range of 2600°k to 3200°k for warm white and 5000° to 6000°k for white. Individual orders are bin-sorted to within plus or minus 100°k and it is recommended to purchase 10% replacement stock within that bin lot to ensure matched color for needed replacements. White LEDs vary slightly in color temperature from bin to bin. Tivoli references each bin location number on the packing list and labels it on each LED product accordingly. During installation, it is very important that like bins are located in close proximity for color consistency. The overall color will visually appear consistent even with multiple bins located in surrounding areas. However, if different bins are located in close proximity there may be slight color variations visible.

For example:  
 Bin No. B-1C  
 Bin No. B-1B

1C should be installed close to each other.  
 1B should be installed close to each other  
 1C and 1B should NOT be installed close to each other.



# COVELUM™ DESIGNER SERIES LED WHITES

## RECOMMENDED POWER SUPPLIES

PART #	PRIMARY AND SECONDARY	TOTAL WATTAGE / AMPERAGE PER BREAKER	LISTING	DIMENSIONS	WEIGHT	ELECTRONIC OR AC MAGNETIC	DIMMABLE (Y OR N)
ADUL-75-1-5-12-D	85-264V AC / 12V DC	75 / 1X5A	UL/ETL	10"W X 10"L X 4"D		Electronic	Y: D & E
ADUL-200-1-15-12-D	85-264V AC / 12V DC	200 / 1X15A	UL/ETL	10"W X 10"L X 4"D		Electronic	Y: D & E
ADUL-200-3-5-12-D	85-264V AC / 12V DC	200 / 3X5A	UL/ETL	10"W X 10"L X 4"D		Electronic	Y: D & E
ADUL-300-5-5-12-D	85-264V AC / 12V DC	300 / 5X5A	UL/ETL	10"W X 10"L X 4"D		Electronic	Y: D & E
QT-200-1-15-12-D	120V AC / 12V DC	200 / 1X15A	cCSAus	14.50"W X 8.00"L X 4.00"D		Magnetic	Y: A
QTH-200-1-15-12-D	277V AC / 12V DC	200 / 1X15A	cCSAus	14.50"W X 8.00"L X 4.00"D		Magnetic	Y: F
QT-400-2-15-12-D	120V AC / 12V DC	400 / 2X15A	cCSAus	14.50"W X 8.00"L X 4.00"D		Magnetic	Y: A
QTH-400-2-15-12-D	277V AC / 12V DC	400 / 2X15A	cCSAus	14.50"W X 8.00"L X 4.00"D		Magnetic	Y: F
QT-600-3-15-12-D	120V AC / 12V DC	600 / 3X15A	cCSAus	14.50"W X 8.00"L X 4.00"D		Magnetic	Y: B, C, D & E
QTH-600-3-15-12-D	277V AC / 12V DC	600 / 3X15A	cCSAus	14.50"W X 8.00"L X 4.00"D		Magnetic	Y: G
JT-60-1-5-12-D	120V AC / 12V DC	60 / 1X5A	ETL	4.25"W X 8.50"L X 3.25"D		Magnetic	Y: A, D & E
JTH-60-1-5-12-D	277V AC / 12V DC	60 / 1X5A	ETL	4.25"W X 8.50"L X 3.25"D		Magnetic	Y: D, E & F
JT-240-4-5-12-D	120V AC / 12V DC	240 / 4X5A	ETL	8.50"W X 16.00"L X 4.50"D		Magnetic	Y: A, D & E
JTH-240-4-5-12-D	277V AC / 12V DC	240 / 4X5A	ETL	8.50"W X 16.00"L X 4.50"D		Magnetic	Y: D, E & F
MT-60-1-5-12-D	100-240V AC / 12V DC	60 / 1X5A	UL	4.25"W X 12.32"L X 4.00"D		Electronic	N

## DIMMERS

SELECTOR	DIMMER	TYPE	CONTROL SIGNAL	INPUT VOLTAGE	OUTPUT VOLTAGE	MAX LOAD	BREAKER RATING	DIMENSIONS
<b>A</b>	N-600	AC Magnetic	N/A	120V AC	120V AC	450W Max.	N/A	Recessed Single gang box
<b>B</b>	N-1000	AC Magnetic	N/A	120V AC	120V AC	800W Max.	N/A	Recessed Dual gang box
<b>C</b>	N-1500	AC Magnetic	N/A	120V AC	120V AC	1200W Max.	N/A	Recessed DUal gang box
<b>D</b>	DIM-12V-8A	DC Digital	N/A	12V DC	12V DC	96W	8A*	Single gang box
<b>E</b>	DIM-OT-1-5-D	Control Interface	1-10VDC	12V DC	12/24V DC	60W	5A**	7"L X 1½"W X ¾"H
<b>F</b>	NH-600	AC Magnetic	N/A	277V AC	277V AC	450W	N/A	Recessed Single gang box
<b>G</b>	NH-1000	AC Magnetic	N/A	277V AC	277V AC	800W	N/A	Recessed Dual gang box

\* AD & QT Series secondary outputs would be limited to 8 amps.

\*\* OTDIM applications require 1 each OTDIM per 5 amp circuit

## PRODUCT SPECIFICATION GUIDE

SPACING	WATTS PER FOOT	PRODUCT MAX RUN LIMITATIONS (Ft/W/LED's)
2.5" O.C.	3.6W/ft	15A or 45ft
3" O.C.	3.0W/ft	15A or 54ft
4" O.C.	2.25W/ft	15A or 72ft

